

焊缝规

975

◆ 不锈钢尺身

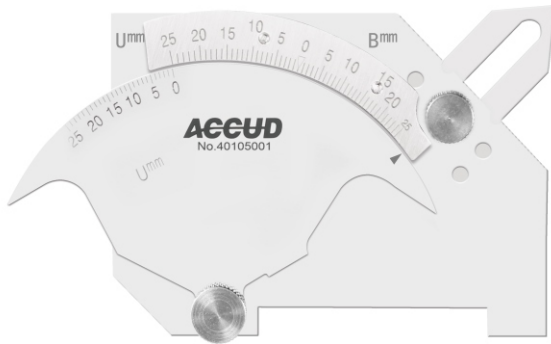

正面

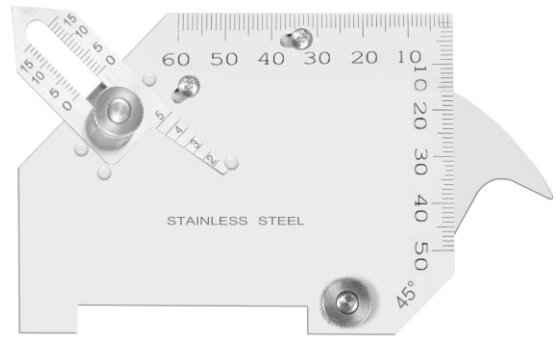

反面

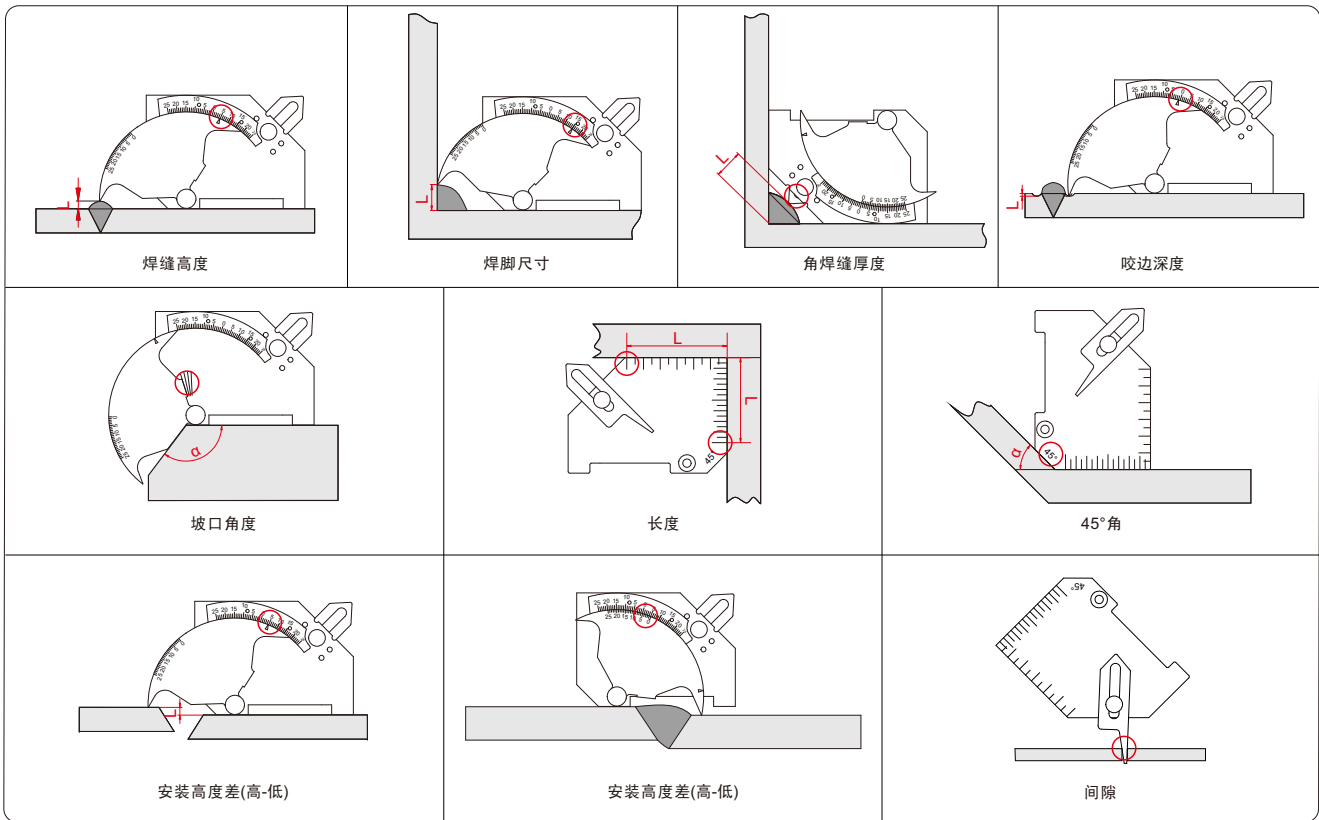

货号	测量项目	厚度范围	分度值	精度
975-025-21	焊缝高度	0-25mm	1mm	±0.5mm
	焊脚尺寸	0-25mm	1mm	±0.5mm
	角焊缝厚度	0-15mm	1mm	±0.5mm
	咬边深度	0-25mm	1mm	±0.5mm
	坡口角度	0-60°	5°	±1°
	长度	0-60mm	1mm	±0.5mm
	45°角	—	—	±1°
	安装误差(高-低)	0-25mm	1mm	±0.5mm
	间隙	2-5mm	1mm	±0.5mm

