

角焊接规

969

- ◆ 标配纸卡
- ◆ 不锈钢材料

纸卡(标配)

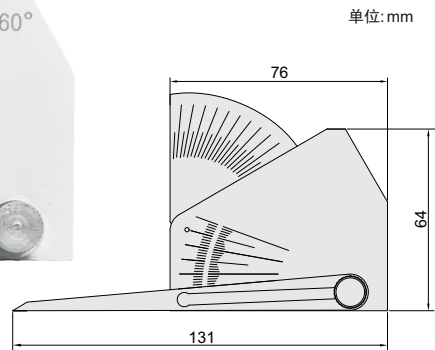
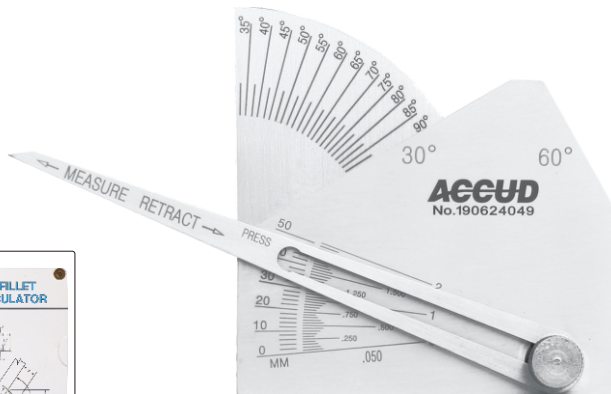
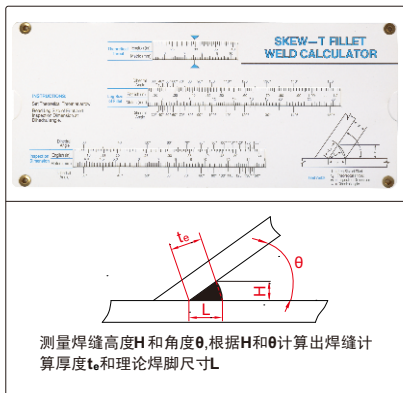

货号	测量项目	量程	分度值	精度
969-050-01	焊缝高度 H	0-50mm/0-2"	2mm/.050"	±1mm
	角度 θ	30° - 90°	2.5°	±1°
	60° 角	-	-	±0.5°

