

角焊接规

745

- ◆ 用于测量凸形焊缝的焊脚尺寸
- ◆ 包含三片
- ◆ 不锈钢尺身

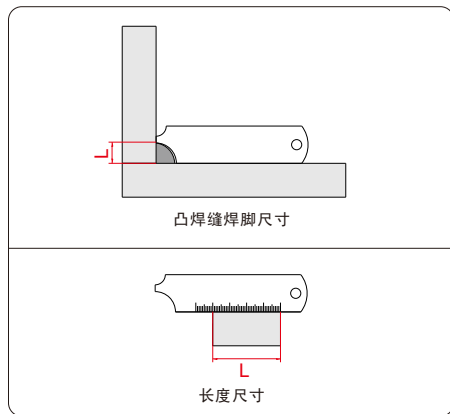

单位: mm

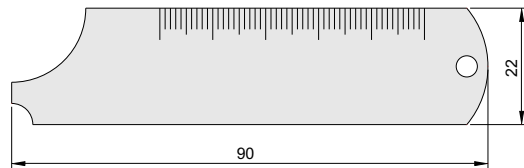

型号	测量项目	量程	分度值	精度
745-050-03	焊脚尺寸	4,6,8,10,12,14mm	—	±0.5mm
	长度	0-50mm	1mm	±0.5mm

