

百分内径量表

251系列

- ◆ 符合JJF内径表国家计量技术规范
- ◆ 可选配校对环规531系列

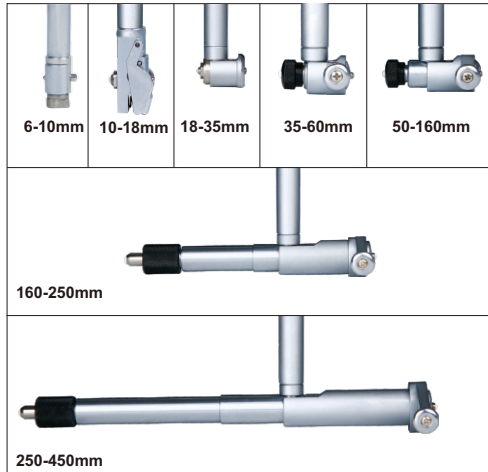

251-160-11

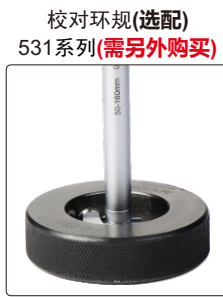
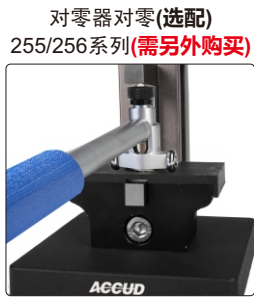
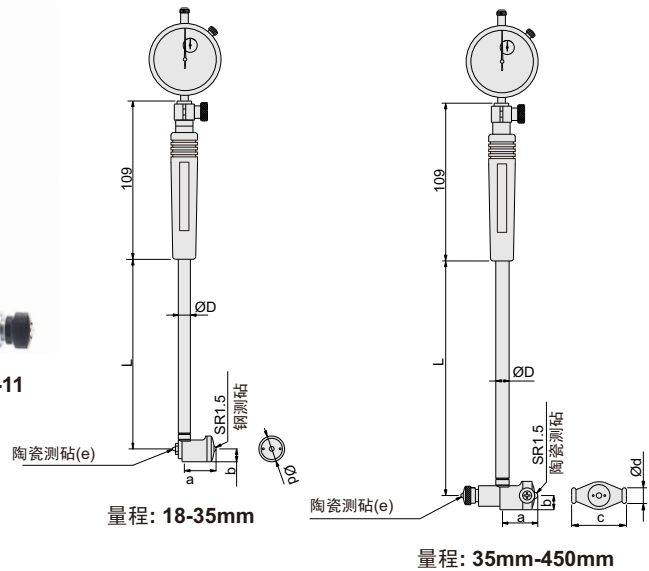
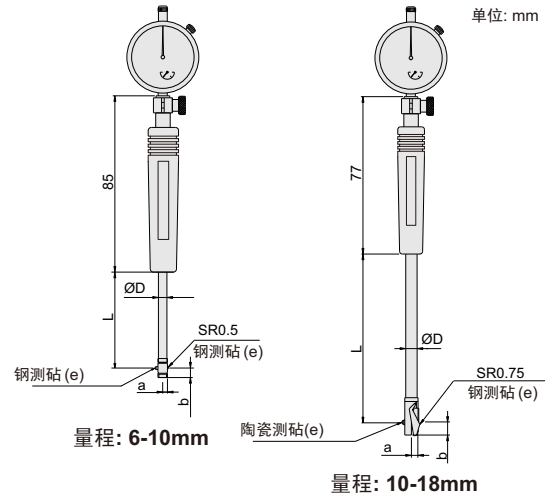

可换测头(标配)



垫片(标配)



215系列(选配)



测头安装

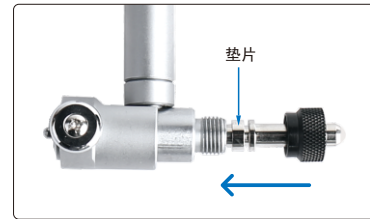

货号	量程	表头	可换测头	垫片	精度	重复性	a	b	c	Ød	ØD	e	L
251-010-11	6-10mm	量程: 3mm 分度值: 0.01mm	9pcs	2pcs	±0.012mm	3µm	3.6	5.7	/	/	4.5	SR1	48
251-018-11	10-18mm		9pcs	2pcs	±0.012mm	3µm	5.6	7.8	/	/	6	SR1	105
251-035-11	18-35mm	量程: 10mm 分度值: 0.01mm	9pcs	2pcs	±0.015mm	3µm	12.2	6.4	/	12.7	9	SR1	141
251-060-11	35-60mm		6pcs	4pcs	±0.018mm	3µm	26	9	27	13	12.8	SR2	141
251-100-11	50-100mm		11pcs	4pcs	±0.018mm	3µm	26	9	35	13	12.8	SR2	141
251-160-11	50-160mm		12pcs	4pcs	±0.018mm	3µm	26	9	35	13	12.8	SR2	141
251-160-12	100-160mm		12pcs	4pcs	±0.018mm	3µm	26	9	35	13	12.8	SR2	141
251-250-11	160-250mm		5pcs	5pcs	±0.018mm	3µm	56.5	13	74.5	15	14.5	SR3.5	400
251-450-11	250-450mm		5pcs	5pcs	±0.018mm	3µm	86.5	15	101.5	15	14.5	SR3.5	400