

圆柱头内径数显卡尺

136

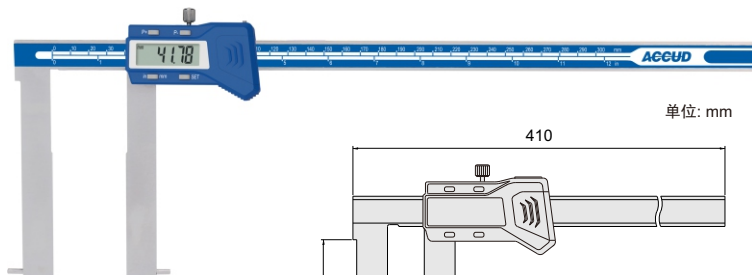

操作视频



单位: mm

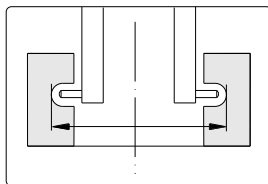
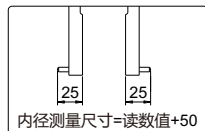
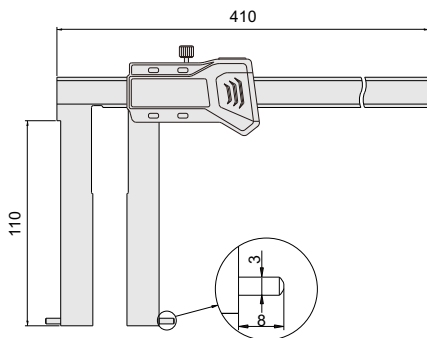

- ◆ 用于测量狭窄内凹处的相关尺寸
- ◆ 分辨率: 0.01mm/0.0005"
- ◆ 按键: 公/英制转换, 设置数值, 数值预置(P+, P-)
- ◆ 滑动开机, 自动关机
- ◆ 带数据输出(数据线货号: 100-03或100-04)
- ◆ 不锈钢尺身

预置按键

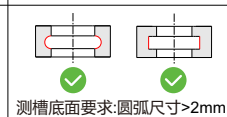
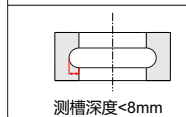
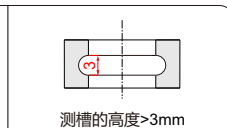
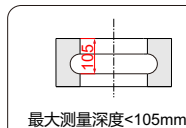
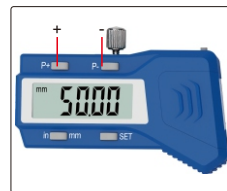

| 货号 | 量程 | 精度 |
|-------------|----------|---------|
| 136-012-13S | 50-300mm | ±0.06mm |