

数显卡尺

119

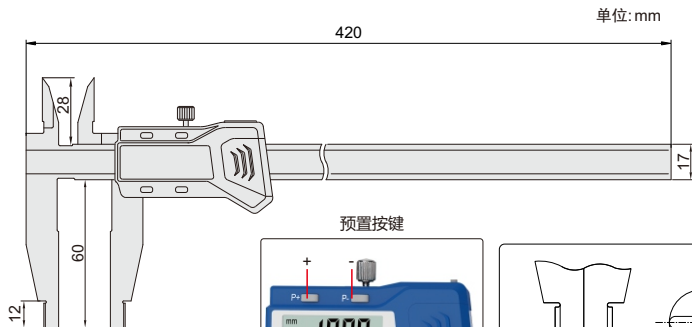

ACEUD

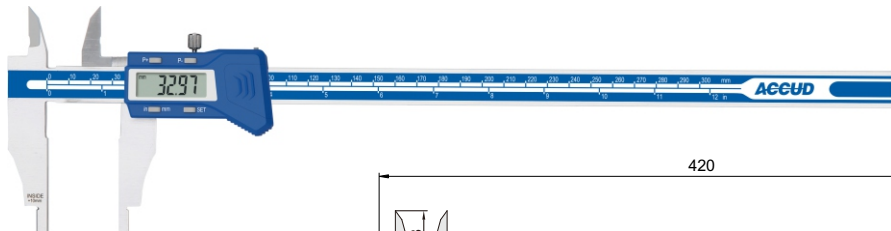

预置按键

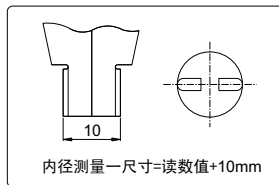
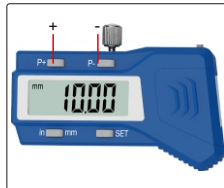

- ◆ 符合JJG通用卡尺国家计量检定规程
- ◆ 分辨率: 0.01mm/0.0005"
- ◆ 按键: 公/英制转换, 设置数值, 数值预置(P+, P-)
- ◆ 带数据输出(数据线货号: 100-03或100-04)
- ◆ 不锈钢尺身

货号	量程	精度
119-012-11	0-300mm/0-12"	±0.04mm

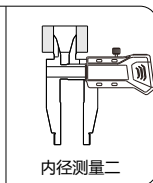
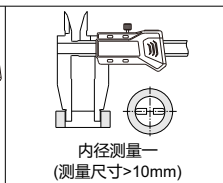

卡尺