

109-006-11

单位: mm

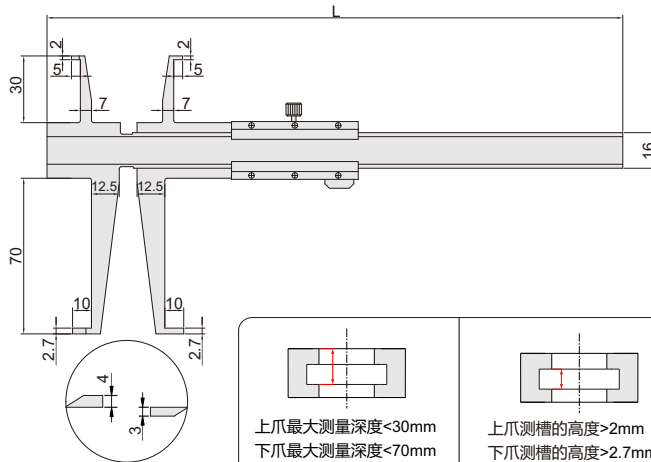

- ◆ 符合JB/T异形卡尺国家机械行业标准
- ◆ 用于测量孔内沟槽
- ◆ 分辨率: 0.02mm
- ◆ 不锈钢尺身
- ◆ 镀暗铬刻度面

货号	上爪量程	下爪量程	精度	L
109-006-11	9-150mm	16-150mm	±0.04mm	260
109-008-11	9-200mm	16-200mm	±0.06mm	310
109-012-11	9-300mm	16-300mm	±0.06mm	415

